

mdvslovakia.sk



IMPACT

HEAT PUMPS

MDV®



Table of contents

Aircon and MDV brand	3
Feel the IMPACT	4
Advanced technological solution	5
Ecology and economy	7
Safety and comfort	9
Complex control – SMART Control System	11
Certificates and ZUM list	13
Subsidy	15
IMPACT All-In-One	16
IMPACT SPLIT	20
IMPACT MONO	24
Unit dimensions	28
Aircon – Product Information	35

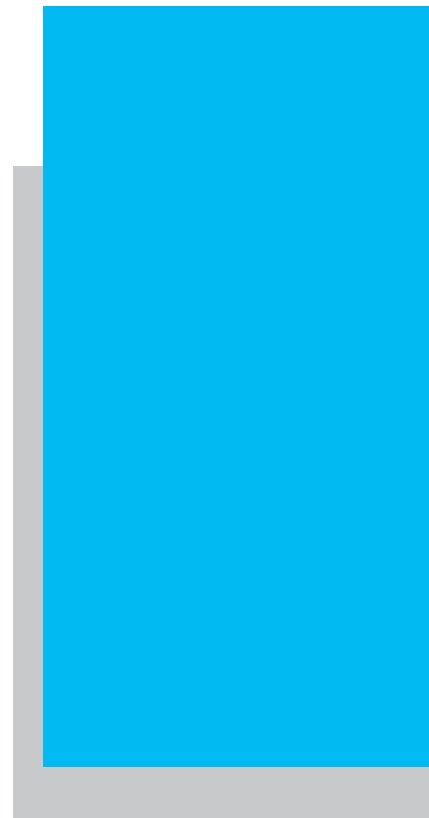

Aircon and MDV brand

We are the general distributor of MDV brand. Our offer is based on a wide range of air-conditioning units – from split and multi type units up to expanded VRF systems. We are distinguished not only by the reliable devices, but also by a team of experts, which supports our customers for 22 years.

Experienced and well-communicated sales support, design, investment, service and marketing team is the foundation for our strong market position. This delivers the certainty of professional service to our clients. Our Partners contribute to the recognition of MDV brand, inter alia, in Czech Republic, Slovakia, Romania, Denmark or Iceland.



Continuous development



Over 11 regional offices in Poland



Hundreds of thousands of sold devices



Fully equipped training room with an area of 420m²



Thousands of trained people



Modern marketing support



Experts with long experience



Innovative technologies and products









Loyalty programs for customers



New products in our offer

Feel the IMPACT

Heating without exhaust fumes and with low current consumption.

-  Maintenance free operation
-  Adapted to meet needs of heating, cooling and domestic hot water
-  Wide operating temperature range and long service life of the compressor
-  No need for a boiler room
-  Complex control from any place thanks to the mobile application
-  Single fan – smaller dimensions, quieter operation

The basis of the heat pump operation is the transfer of heat. In the heating mode, the heat is collected from the lower source and transferred to the upper source. The lower source is the energy present in air, water or brine. This means, that the heat pump uses a renewable resource available outside, whereby in case of the IMPACT units, it is the easiest to access resource: the atmospheric air. The upper source is the central heating installation and domestic hot water circuit. To do this, it is necessary to transfer the medium, which is heat, from the lower to the upper level, which is the process of pumping.

Because the heat pump provides transfer of heat that is accessible outside, instead of generating heat, it is possible to obtain several times lower electric energy consumption than with use of the conventional electric heating. The electric heaters, in order to generate 1 kWh of heat, always need to consume 1 kWh

of electric energy, what means that electric heater COP (delivered thermal energy [W] /consumed electric energy [W]) cannot exceed 1.

Heat pumps use electric energy only to transfer heat, what means that after consuming 1 kWh of electric energy, it is possible to supply a building with many kWh of heat. The higher COP coefficient, the lower electric energy demand for the same site, and hence a reduction of electricity bills.

The IMPACT heat pumps feature high COP coefficient of performance, which is 5.2 for A7/W35 conditions, and seasonal space heating energy efficiency class is A+++. Moreover, the thermodynamic cycle operates in wide temperature range: -25°C (in heating and DHW production modes) and +43°C (in cooling mode).

Advanced technological solution

Twin-Rotary DC Compressor

- Twin-Rotary Compressor
Efficient vibration reduction thanks to the application of the twin eccentric discs and two balance weights.
This provides lower noise and energy loss.
- Effects of improved compressor drive technology:
 - compact construction
 - greater bearing durability
- Materials resistant to high pressure
Wide operating temperature range – reachable top temperature of 65°C
- DC Inverter Technology
Smooth optimisation of operation parameters

An intelligent design of the fan: quiet operation

- Fan blades are formed to provide uniform airflow, resulting in reduction of energy consumption by 30%.
- Fan blades have special grooves which limit the intake vortex. The result is also lower weight of the fan.
- Thickening of the leading edge causes reduction of the low frequency noise, and additionally strengthens the blade structure.

Variable adjusted fan motor with DC/AC inverter

- The motors can operate with many different speeds, which allow for more optimum air-flow adjustment to the current load, resulting from, among others, weather conditions. Variable adjustment of fan rotation and equally accurate compressor operation control, represent a key aspect of the possible safe floor drying.
- Possible to downsize the fan motor by 35% and reduce energy consumption.





MD

Ecology and economy

Smart Grid

The IMPACT heat pump energy consumption can be automatically adjusted, according to the peak or off-peak power being used.

Adaptation of the energy intake is aimed to maximise the reduction of heating costs.

Such an adjustment of energy consumption is determined as "interaction with the Smart Power Grids". The IMPACT heat pumps have achieved adequate results, necessary to use the SG Ready label, which confirms the effectiveness of performance.

Energy usage monitoring

A mobile application provides analysis of electric energy intake (daily, weekly, monthly or annual consumption), enabling user to optimise its settings for reduction of running costs and anticipation of bills.

Control of the auxiliary heat source

A bivalent heat source, like gas boiler or another heating appliance, can be connected and controlled within the installation.

Environment friendly heat pumps – High COP 5.2*

In Poland, electric energy is mainly produced by combustion of coal and oil derivatives.

Cutting the electricity consumption reduces the environmental impact.

With such a coefficient of performance, the heat pump uses 81% of renewable energy present in air.

* for supply water temperature 35°C and air temperature 7°C.

Solar system control

With solar collectors it is possible to choose solar source function on the controller. DHW production supported by the collectors, provides system control, thereby reducing the heat pump operation.



ECO mode

This mode allows for a reduction of energy input from the mains power source, according to the choice of one of eight power limitation levels. User can set the time period for operating this function (timer).

R32 vs. R410A – strengths of the R32 refrigerant

- ▶ Higher heat transfer coefficient (improved performance and efficiency)
- ▶ 75% lower global warming potential
- ▶ Reduction of refrigerant charge necessary for a pump with the same capacity by 30%
- ▶ One of the safest and nontoxic refrigerants

Safety and comfort

Disinfection function

- The need of DHW tank disinfection results from the risk of Legionella bacteria growth when the tank is not used for a lengthy period of time, for instance by reason on holidays away from home). Legionella represents a serious threat to the digestive system. User can easily set the automatic disinfection function, which consists in rising the temperature up to 70° C, immediately killing bacteria.

Floor preheating and drying function

- Phenomenon of too fast drying of the damp floor results in contraction of floor material (screed or wood) and consequently its warping or cracking. Thanks to the stepless compressor control, this function prevents too high temperature from occurring on the floor.

Auxiliary heater

- In the case of extremely high heat demand, the bivalent electric heater is turned on. IMPACT models with capacity of 4 and 6 kW are equipped with a 3 kW heater. Higher capacity models are equipped with 9 kW heater.
- 9 kW heater has been designed to operate in 3 capacity steps (3,6 and 9 kW) for its better adaptation.

Holiday away mode

- Prior to departure, a user can run the holiday away mode. The supply water temperature will then be lowered in order to save electric energy. The system will hold temperature on a specified level to protect the circuit from freezing during winter. In addition to savings of cost, it also guarantees safety.

Holiday home mode

- It allows to stop immediately the standard weekly schedule, while heating and cooling modes operate to guarantee stable conditions for the user.

Quiet operation

- A solution based on the innovative rotor blade structure, and also effectively sound insulated components of the outdoor and indoor unit.



Quiet mode (1st level)

- Accomplished by reduction of fan speed.

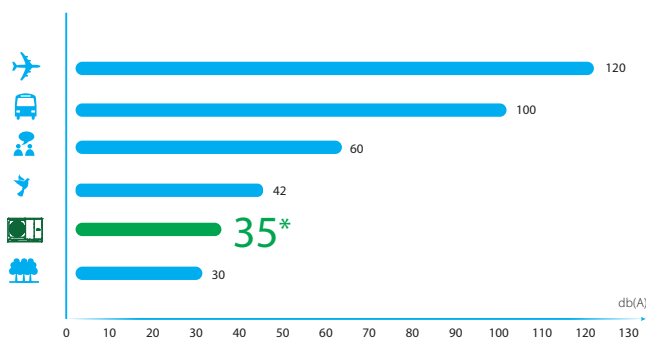
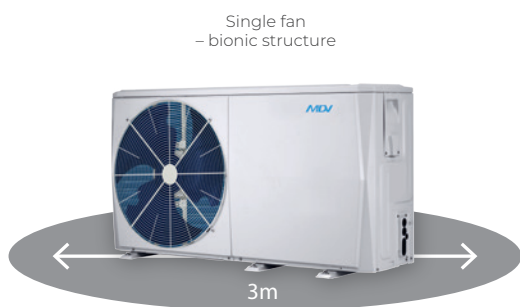

*Dotyczy ciśnienia akustycznego jednostki NXHPM-V4W/D2N8-BER30 mierzonego z odległości 3 metrów

Super quiet mode (2nd level)

- Further noise reduction is achieved by lowering frequency of both, the fan and the compressor.

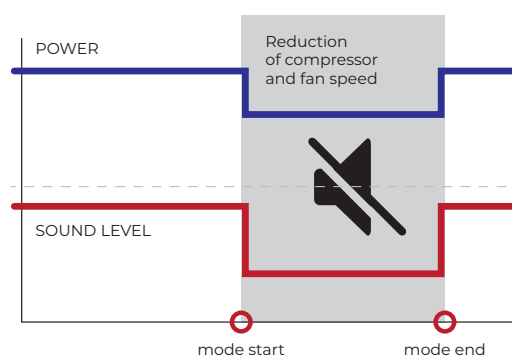

Dual zone temperature control

- For better control of room temperature adjustment, and in consequence, comfort improvement, it is possible to manage dual zones. Mixed heating, which includes use of radiators or fan-coils together with floor heating, is a common solution. IMPACT heat pumps controller provides independent temperature control of water supplying the radiators and floor heating.

Fast DHW heating

- In the case of huge DHW demand it is possible (after setting the DHW priority function) to use the increased heating capacity. Heat pump and booster heater are turned on simultaneously, which provides faster DHW production.



Complex control

– SMART Control System

IMPACT heat pumps equipment includes wired remote controller, which provide the full control of the central heating and DHW systems from the controller as well as from the mobile application. The controller features a touch screen, intuitive Polish menu, a built-in temperature sensor and Modbus protocol available as standard.

During the initial start-up, operation settings and parameters are set according to the end user's preferences. This provides better adaptation of operation and pump functionality.

System functionality and capabilities:

- ▶ Setting temperature and mode (heating, cooling, DHW, auto, mixed);
- ▶ System, heat pump status and its operating mode monitoring;
- ▶ Temperature display: current, set, outdoor and tank water;
- ▶ Display of time set in 12- or 24-hour format;
- ▶ Error code display;
- ▶ Component status display;
- ▶ Test mode setting (checking components operation);
- ▶ Cascade system control available (up to 6 units);
- ▶ Disinfection function on/off, fast DHW production, holiday home, holiday away, ECO mode, quiet mode;
- ▶ Solar installation on/off;
- ▶ Daily and weekly schedule (up to 6 groups of settings);
- ▶ RTU ModBus protocol, enabling connection of up to 16 units into an integrated BMS system.

Heating zones control

It is possible to precisely control two independent heating systems from the controller (or from the mobile application): radiator heating, floor heating and other configurations. Users can also set different temperature for different rooms, according to individual needs, what allows for flexible and better coordinated control over the central heating system.

Control from the mobile application (Wi-Fi)

The user has the possibility of full control from any place with use of the Comfort Home application. In addition, the energy consumption monitoring and guidance on energy saving are available here.

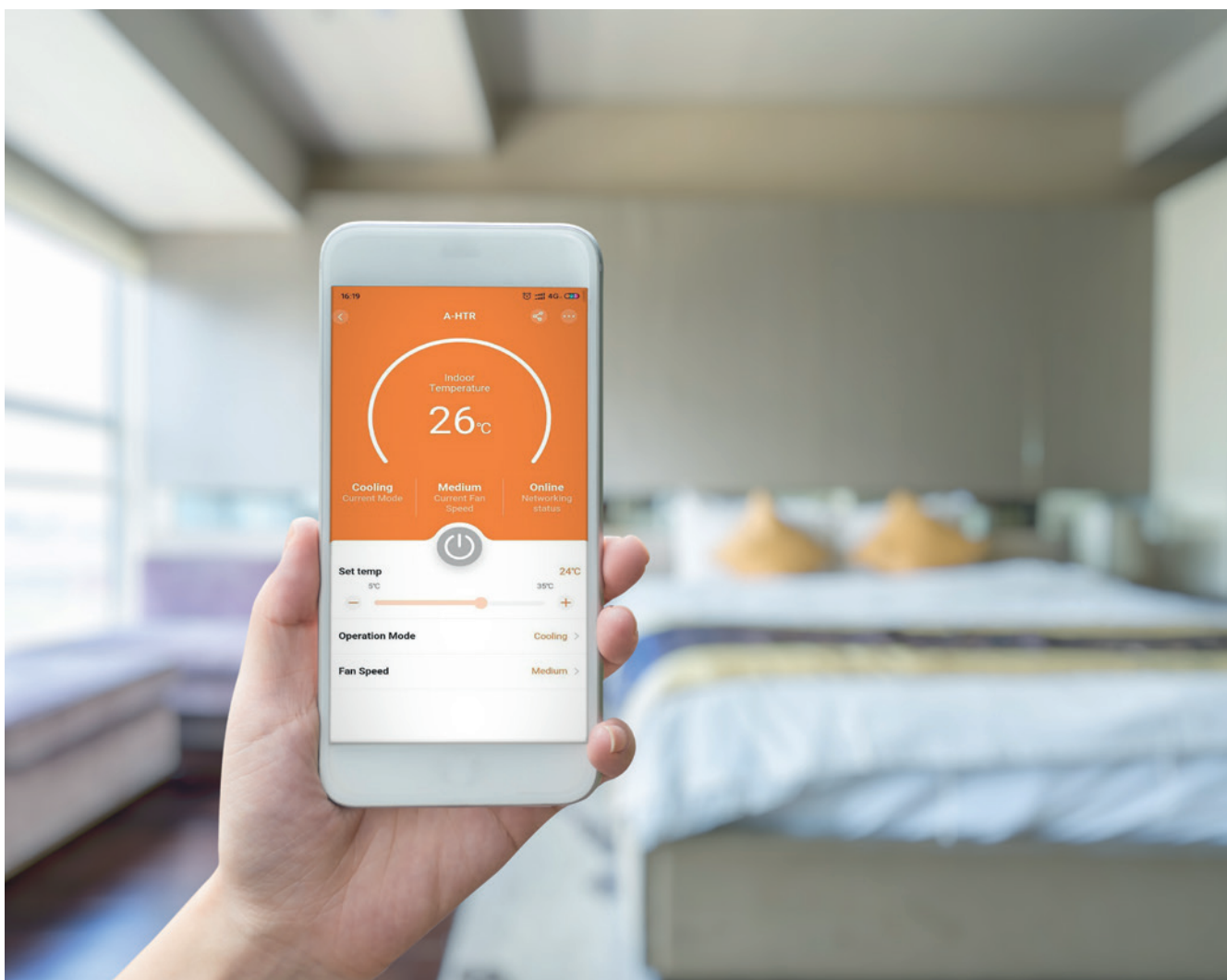

Daily and weekly timer

As to provide the best adaptation of the heat pump operation to the individual user's needs, it is possible to plan the heating/cooling temperature and operating mode for two zones for a specified day or the whole week. In the case of need to interrupt immediately the schedule, without deleting it, the user can set the holiday home mode (if the user is present) or holiday away (when the user is absent).

Certificates and ZUM list

EUROVENT

Eurovent stands for standardisation of technical data for air-conditioning equipment in accordance with European and international standards. This enables purchaser of the units or systems to identify to which energy class does the unit belong. This certificate confirms the validity of technical specification provided by the manufacturer, such as capacity, energy consumption and sound levels.



KEYMARK

This is a certificate that confirms that the units comply with the requirements laid down in Ecodesign Directive of the European Parliament, which deals with the emission-energetic requirements. This certificate constitutes the sufficient proof of quality for subsidy programs like "Clean Air". A purchaser receives a guarantee of quality, since Keymark evaluates not only the product, but also manufacturer's production facilities. This mark is commonly recognized in countries which have representatives in the European Commission.



MCS

It provides evidence that the contractor implements adequate processes and appropriate tools. One of the issues are installations equipped with the air-conditioning units. Installations made under the certification system must be registered in the MCS data base.



CE

This label has a particularly important function in the EU. This marking was created to eliminate barriers in the movement of goods. Member States may not prohibit placing a CE marked product on its market. Products with CE marking must meet the requirements of the "New Approach" EU directive. These directives relate to safety in use, health and environment protection.



ZUM – List of Green Equipment and Materials

The ZUM list is a register of devices that meet the requirements of the "Clean Air" programme. It also includes a summary of certificates and other documents concerning the product.





Subsidy

„Clean Air” programme

For landlords and co-owners of detached houses who wish to make thermal upgrade of the heat source. It is also a co-financing for carrying out thermal upgrade works of the facility. The entity must meet one of these two conditions:

- an average monthly income per household member shall not exceed PLN 1,400 in the case of multi-person households or PLN 1,960 in the case of individual households – subsidy up to PLN 37,000;
- an annual income shall not exceed PLN 100,000 – subsidy up to PLN 25,000.

Visit the website: czystepowietrze.gov.pl

„My heat” programme

For people who plan to install a heat pump in buildings with a higher energy standard, i.e. those for which the demand for primary energy does not exceed 55 kWh (calculated per square meter of building, annually). There is no income threshold here, as it is the case with the “Clean Air” program. This subsidy covers the purchase and installation of a heat pump. Subsidies range from PLN 7,000 to PLN 21,000.

Visit the website: mojecieplo.gov.pl

“Agroenergy” programme

For individual farmers who plan to connect new units generating energy from renewable sources, including heat pumps, to the distribution network. The subsidy provides for preferential loans up to 100% of eligible costs and subsidies up to 40% of eligible costs (up to PLN 800,000).

Visit the website: www.gov.pl/web/nfosisgw/czesc-1-mikroinstalacje-pompy-ciepla-i-towarzyszace-magazyny-energii

Thermal upgrade tax credit

When replacing heat sources with a low energy class with devices with lower pollution emission, it is possible to take advantage of deductions from income tax (depending on the cost of thermal upgrade). A deduction of up to PLN 53,000 per person is allowed and the owners and co-owners of the house undergoing an upgrade are entitled to the credit..

IMPACT All-In-One

IMPACT All-In-One heat pump is a set that can be used in exchange with a DHW tank, that as a separate installation module, needs additional space. Hydraulic modules All-In-One is designed to reduce the dimensions, and the integrated tank is placed directly under the hydraulic components. Occupied surface is only 0.36 m².



Exemplary applications

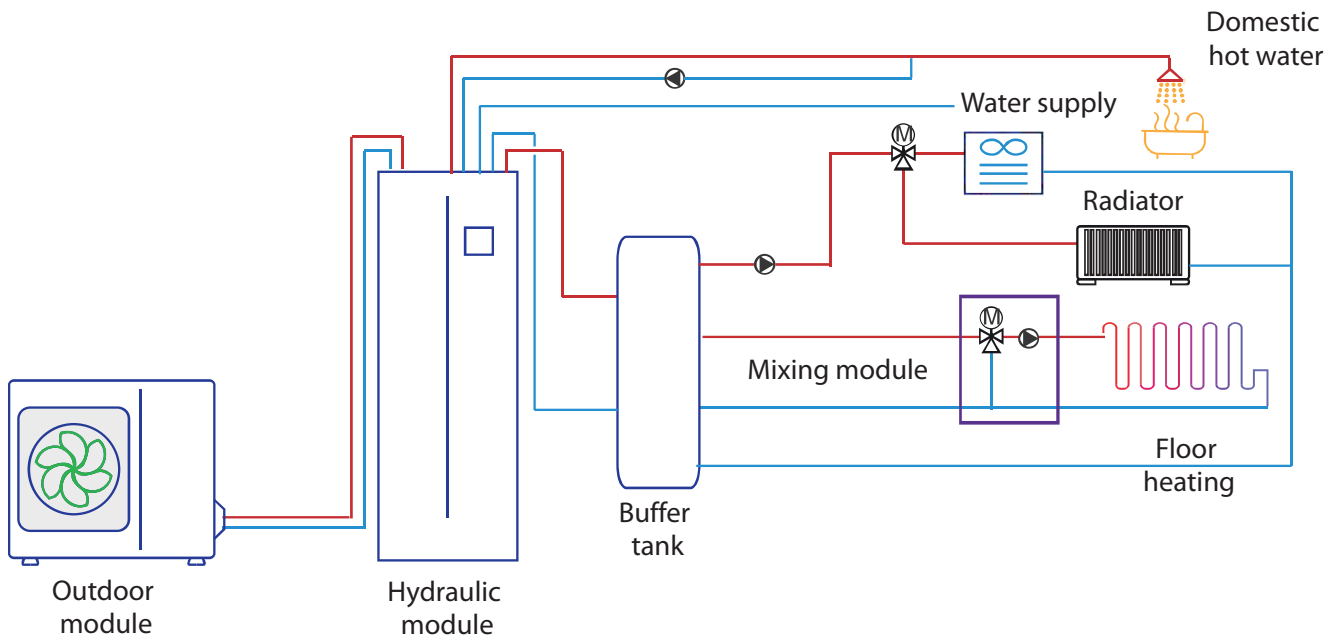

System no. 1: Installation with the All-In-One system using a mixing module

The indoor hydraulic module is responsible for both production of domestic hot water and its storage. In addition, it can be connected to the central heating installation. A buffer tank is used as a heat storage. Mixing valves provide more optimal heating with radiators and floor heating.



Specifications

Set			MDV-AiO-4A1/190	MDV-AiO-4A1/240	MDV-AiO-6A1/190
Outdoor unit			AHPS-V4W/D2N8-B	AHPS-V4W/D2N8-B	AHPS-V6W/D2N8-B
Hydraulic module			AHBT-A100/190CD30GN8-B	AHBT-A100/240CD30GN8-B	AHBT-A100/190CD30GN8-B
Outdoor unit power supply (voltage/phases/frequency)		(V/-/Hz)	220-240/1/50	220-240/1/50	220-240/1/50
Hydraulic module power supply (voltage/phases/frequency)		(V/-/Hz)	220-240/1/50	220-240/1/50	220-240/1/50
Heating (1) (A7/W35)	Capacity	kW	4.25	4.25	6.20
	COP	-	5.20	5.20	5.00
Heating (2) (A7/W45)	Capacity	kW	4.35	4.35	6.35
	COP	-	3.80	3.80	3.75
Cooling (3) (A35/W7)	Capacity	kW	4.70	4.70	7.00
	EER	-	3.46	3.46	3.00
Cooling (4) (A35/W18)	Capacity	kW	4.50	4.50	6.55
	EER	-	5.55	5.55	4.90
Electric heater power		kW	3	3	3
Seasonal energy efficiency class (5)	Water inlet temperature 35°C	-	A+++	A+++	A+++
	Water inlet temperature 55°C	-	A++	A++	A++
Outdoor temperature range	Cooling	°C	-5÷43	-5÷43	-5÷43
	Heating	°C	-25÷35	-25÷35	-25÷35
	Domestic hot water	°C	-25÷43	-25÷43	-25÷43
Water inlet temperature range	Cooling	°C	5~25	5~25	5~25
	Heating	°C	25~65	25~65	25~65
	Domestic hot water	°C	20~60	20~60	20~60
Sound power level (outdoor unit)		dB(A)	56	56	58
Sound power level (hydraulic module)		dB(A)	38	38	38
Outdoor fan	Motor type/no. of fans	-	DC/1	DC/1	DC/1
Maximum installation length		m	30	30	30
Maximum height difference		m	20	20	20
Refrigerant (type/charge)		-/kg	R32/1.5	R32/1.5	R32/1.5
Outdoor unit	Dimensions (length/height/depth)	mm	1008×712×426	1008×712×426	1008×712×426
	Transport dimensions (length/height/depth)	mm	1065×810×485	1065×810×485	1065×810×485
Hydraulic module	Dimensions (length/height/depth)	mm	600×1683×600	600×1943×600	600×1683×600
	Transport dimensions (length/height/depth)	mm	653×1900×653	653×2160×653	653×1900×653
Net weight (outdoor unit)		kg	60	60	60
Net weight (hydraulic module)		kg	140	157	140

(1) DB/WB 7/6°C, LWT 35°C (ΔT = 5°C)

(2) DB/WB 7/6°C, LWT 45°C (ΔT = 5°C)

(3) DB 35°C, LWT 7°C (ΔT = 5°C)

(4) DB 35°C, LWT 18°C (ΔT = 5°C)

(5) Seasonal space heating energy efficiency class tested in average climate conditions.

(6) Sound pressure level measured at a distance of 1 m from the unit and (1+H)/2 m (where H is the height of the unit) above the floor in the semi-anechoic chamber.

The sound pressure level is tested in the following conditions:

Outdoor air temperature 7°C DB, 85% R.H.; inlet water temperature 30°, outlet water temperature 35°C.

Outdoor air temperature 7°C DB, 85% R.H.; inlet water temperature 47°, outlet water temperature 55°C.

Related standards and legislation: EN14511; EN14825; EN50564; EN12102; (EU) No 811/2013; (EU) No 813/2013; OJ 2014/C 207

MDV-AiO-6A1/240	MDV-AiO-8A1/190	MDV-AiO-8A1/240	MDV-AiO-10A1/190	MDV-AiO-10A1/240	MDV-AiO-12A3/240
AHPS-V6W/D2N8-B	AHPS-V8W/D2N8-B	AHPS-V8W/D2N8-B	AHPS-V10W/D2N8-B	AHPS-V10W/D2N8-B	AHPS-V12W/D2RN8-B
AHBT-A100/240CDS30GN8-B	AHBT-A100/190CDS90GN8-B	AHBT-A100/240CDS90GN8-B	AHBT-A100/190CDS90GN8-B	AHBT-A100/240CDS90GN8-B	AHBT-A160/240CDS90GN8-B
220-240/1/50	220-240/1/50	220-240/1/50	220-240/1/50	220-240/1/50	380-415/3/50
220-240/1/50	380-415/3/50	380-415/3/50	380-415/3/50	380-415/3/50	380-415/3/50
6.20	8.30	8.30	10.00	10.00	12.10
5.00	5.20	5.20	5.00	5.00	4.95
6.35	8.20	8.20	10.00	10.00	12.30
3.75	3.95	3.95	3.80	3.80	3.80
7.00	7.40	7.40	8.20	8.20	11.60
3.00	3.38	3.38	3.31	3.31	2.75
6.55	8.40	8.40	10.00	10.00	12.00
4.90	5.05	5.05	4.80	4.80	4.00
3	3/6/9	3/6/9	3/6/9	3/6/9	3/6/9
A+++	A+++	A+++	A+++	A+++	A+++
A++	A++	A++	A++	A++	A++
-5÷43	-5÷43	-5÷43	-5÷43	-5÷43	-5÷43
-25÷35	-25÷35	-25÷35	-25÷35	-25÷35	-25÷35
-25÷43	-25÷43	-25÷43	-25÷43	-25÷43	-25÷43
5~25	5~25	5~25	5~25	5~25	5~25
25~65	25~65	25~65	25~65	25~65	25~65
20~60	20~60	20~60	20~60	20~60	20~60
58	59	59	60	60	64
38	40	40	40	40	44
DC/1	DC/1	DC/1	DC/1	DC/1	DC/1
30	30	30	30	30	30
20	20	20	20	20	20
R32/1.5	R32/1.65	R32/1.65	R32/1.65	R32/1.65	R32/1.84
1008×712×426	1118×865×523	1118×865×523	1118×865×523	1118×865×523	1118×865×523
1065×810×485	1190×970×560	1190×970×560	1190×970×560	1190×970×560	1190×970×560
600×1943×600	600×1683×600	600×1943×600	600×1683×600	600×1943×600	600×1943×600
653×2160×653	653×1900×653	653×2160×653	653×1900×653	653×2160×653	653×2160×653
60	78.5	78.5	78.5	78.5	112
157	140	157	140	157	159

IMPACT SPLIT

SPLIT series is a set of an outdoor unit and a hydraulic module. The refrigerant piping is required, what means the installation can only be done by the professionals holding F-gas certification. Nonetheless, this solution has its assets (as compared to the monoblock systems):

- ▶ R32 refrigerant does not freeze in winter. Its temperature of freezing is -136°C .
- ▶ Outdoor units needs less space and are lighter.
- ▶ More easily accessible hydraulic parts and simplified maintenance works.



Exemplary applications

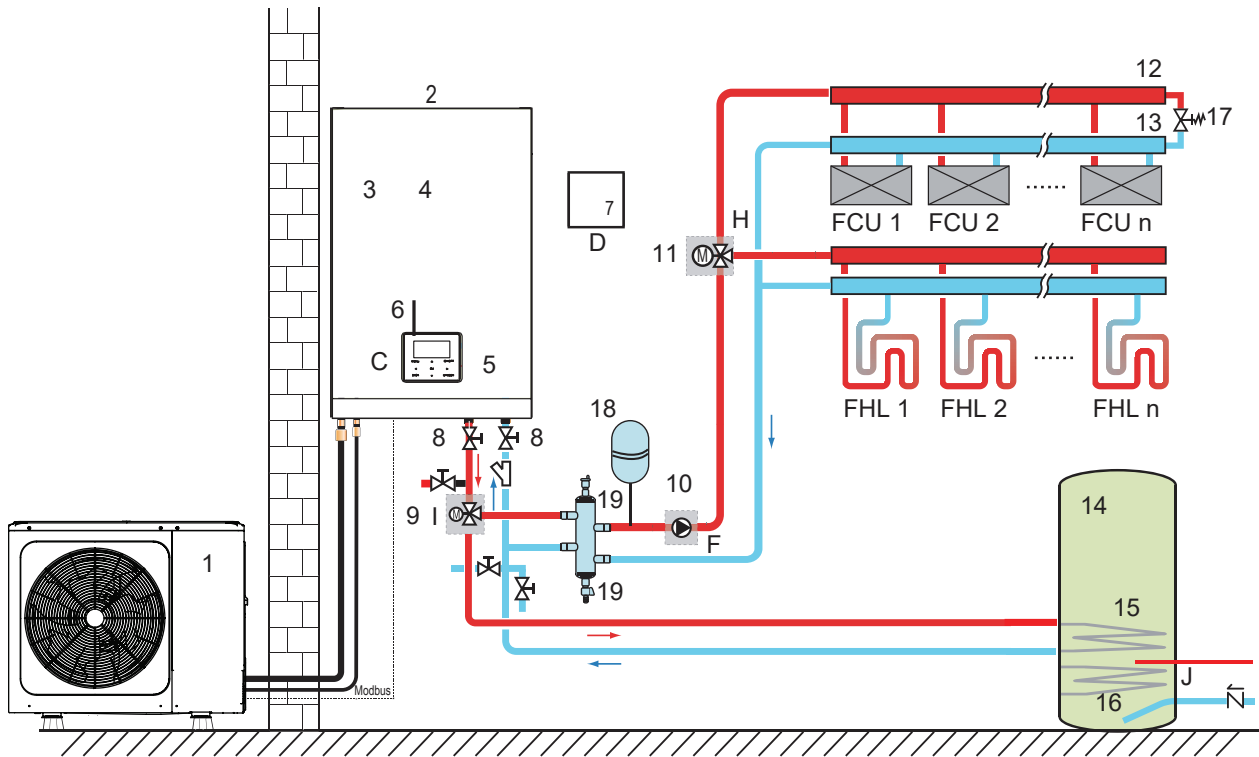

System no. 2: Installation with the Split system, using fan-coils for space cooling

A floor heating loop is applied for the space heating to provide optimum temperature distribution. While fan-coils are responsible for space cooling. Domestic hot water is taken from the DHW tank, connected to the indoor hydraulic module. The heat pump switches to the heating or cooling mode, depending on the room temperature.

In the cooling mode, the 3-way valve (11) is closed in order to prevent cold water from entering the floor heating loop. Cooling through the floor heating loops can lead to condensation on the floor and this may damage the parquet.

1	Outdoor unit	12	Distributor – supply (field supply)
2	Hydraulic module (indoor unit)	13	Distributor – return (field supply)
3	Plate heat exchanger	14	Domestic hot water tank (field supply)
4	Electric heater	15	Heat exchanger coil (field supply)
5	Circulating pump integrated with the hydraulic module	16	DHW tank electric heater (field supply)
6	Wired remote controller	17	Stop valve (field supply)
7	Room thermostat (field supply)	FHL	Floor heating loops (field supply)
8	Stop valves on supply and return (field supply)	FCU	Fan-coils (field supply)
9	Automatic 3-way valve (field supply)	18	Naczynie wzbiorcze (nie należy do wyposażenia)
10	External circulating pump (field supply)	19	Sprzęgło hydrauliczne (nie należy do wyposażenia)
11	Automatic 3-way valve (field supply)		

Specifications

Set			Air-Thermal-4A1HB	Air-Thermal-6A1HB	Air-Thermal-8A1HB
Outdoor unit			AHPS-V4W/D2N8-B	AHPS-V6W/D2N8-B	AHPS-V8W/D2N8-B
Hydraulic module			AHB-A60/ CD30GN8-B	AHB-A60/ CD30GN8-B	AHB-A100/ CDS90GN8-B
Outdoor unit power supply (voltage/phases/frequency)		(V/-/Hz)	220-240/1/50	220-240/1/50	220-240/1/50
Hydraulic module power supply (voltage/phases/frequency)		(V/-/Hz)	220-240/1/50	220-240/1/50	380-415/3/50
Heating (1) (A7/W35)	Capacity	kW	4.25	6.20	8.30
	COP	-	5.20	5.00	5.20
Heating (2) (A7/W45)	Capacity	kW	4.35	6.35	8.20
	COP	-	3.80	3.75	3.95
Cooling (3) (A35/W7)	Capacity	kW	4.70	7.00	7.40
	EER	-	3.46	3.00	3.38
Cooling (4) (A35/W18)	Capacity	kW	4.50	6.55	8.40
	EER	-	5.55	4.90	5.05
Electric heater power		kW	3	3	3/6/9
Seasonal energy efficiency class (5)	Water inlet temperature 35°C	-	A+++	A+++	A+++
	Water inlet temperature 55°C	-	A++	A++	A++
Outdoor temperature range	Cooling	°C	-5~43	-5~43	-5~43
	Heating	°C	-25~35	-25~35	-25~35
	Domestic hot water	°C	-25~43	-25~43	-25~43
Water inlet temperature range	Cooling	°C	5~25	5~25	5~25
	Heating	°C	25~65	25~65	25~65
	Domestic hot water	°C	20~60	20~60	20~60
Sound power level (outdoor unit)		dB(A)	56	58	59
Sound power level (hydraulic module)		dB(A)	38	38	42
Sound pressure level (outdoor unit) (6)		dB	44	45	46
Outdoor fan	Motor type/no. of fans	-	DC/1	DC/1	DC/1
Maximum installation length		m	30	30	30
Maximum height difference		m	20	20	20
Refrigerant (type/charge)		-/kg	R32/1.5	R32/1.5	R32/1.65
Outdoor unit	Dimensions (length/height/depth)	mm	1008×712×426	1008×712×426	1118×865×523
	Transport dimensions (length/height/depth)	mm	1065×810×485	1065×810×485	1190×970×560
Hydraulic module	Dimensions (length/height/depth)	mm	420×790×270	420×790×270	420×790×270
	Transport dimensions (length/height/depth)	mm	525×1050×360	525×1050×360	525×1050×360
Net weight (outdoor unit)		kg	58	58	75
Net weight (hydraulic module)		kg	37	37	37

(1) DB/WB 7/6°C, LWT 35°C (ΔT = 5°C)

(2) DB/WB 7/6°C, LWT 45°C (ΔT = 5°C)

(3) DB 35°C, LWT 18°C (ΔT = 5°C)

(4) DB 35°C, LWT 7°C (ΔT = 5°C)

(5) Seasonal space heating energy efficiency class tested in average climate conditions.

(6) The sound pressure level conditioned: EN12102-1

(7) Sound pressure level measured at a distance of 1 m from the unit and (1+H)/2 m (where H is the height of the unit) above the floor in the semi-anechoic chamber.

The sound pressure level is tested in the following conditions:

Outdoor air temperature 7°C DB, 85% R.H.; inlet water temperature 30°, outlet water temperature 35°C.

Outdoor air temperature 7°C DB, 85% R.H.; inlet water temperature 47°, outlet water temperature 55°C.

Air-Thermal-10A1HB	Air-Thermal-12A1HB	Air-Thermal-14A1HB	Air-Thermal-16A1HB	Air-Thermal-12A3HB	Air-Thermal-14A3HB	Air-Thermal-16A3HB
AHPS-V10W/ D2N8-B	AHPS-V12W/ D2N8-B	AHPS-V14W/ D2N8-B	AHPS-V16W/ D2N8-B	AHPS-V12W/ D2RN8-B	AHPS-V14W/ D2RN8-B	AHPS-V16W/ D2RN8-B
AHB-A100/ CDS90GN8-B	AHB-A160/ CDS90GN8-B	AHB-A160/ CDS90GN8-B	AHB-A160/ CDS90GN8-B	AHB-A160/ CDS90GN8-B	AHB-A160/ CDS90GN8-B	AHB-A160/ CDS90GN8-B
220-240/1/50	220-240/1/50	220-240/1/50	220-240/1/50	380-415/3/50	380-415/3/50	380-415/3/50
380-415/3/50	380-415/3/50	380-415/3/50	380-415/3/50	380-415/3/50	380-415/3/50	380-415/3/50
10.00	12.10	14.50	16.00	12.10	14.50	16.00
5.00	4.95	4.70	4.50	4.95	4.70	4.50
10.00	12.30	14.20	16.00	12.30	14.20	16.00
3.80	3.80	3.65	3.60	3.80	3.65	3.60
8.20	11.60	12.70	14.00	11.60	12.70	14.00
3.31	2.75	2.55	2.45	2.75	2.55	2.45
10.00	12.00	13.50	14.90	12.00	13.50	14.90
4.80	4.00	3.60	3.40	4.00	3.60	3.40
3/6/9	3/6/9	3/6/9	3/6/9	3/6/9	3/6/9	3/6/9
A+++	A+++	A+++	A+++	A+++	A+++	A+++
A++	A++	A++	A++	A++	A++	A++
-5~43	-5~43	-5~43	-5~43	-5~43	-5~43	-5~43
-25~35	-25~35	-25~35	-25~35	-25~35	-25~35	-25~35
-25~43	-25~43	-25~43	-25~43	-25~43	-25~43	-25~43
5~25	5~25	5~25	5~25	5~25	5~25	5~25
25~65	25~65	25~65	25~65	25~65	25~65	25~65
20~60	20~60	20~60	20~60	20~60	20~60	20~60
60	64	65	68	64	65	68
42	43	43	43	43	43	43
49	50	51	55	50	51	55
DC/1	DC/1	DC/1	DC/1	DC/1	DC/1	DC/1
30	30	30	30	30	30	30
20	20	20	20	20	20	20
R32/1.65	R32/1.84	R32/1.84	R32/1.84	R32/1.84	R32/1.84	R32/1.84
1118×865×523	1118×865×523	1118×865×523	1118×865×523	1118×865×523	1118×865×523	1118×865×523
1190×970×560	1190×970×560	1190×970×560	1190×970×560	1190×970×560	1190×970×560	1190×970×560
420×790×270	420×790×270	420×790×270	420×790×270	420×790×270	420×790×270	420×790×270
525×1050×360	525×1050×360	525×1050×360	525×1050×360	525×1050×360	525×1050×360	525×1050×360
75	97	97	97	112	112	112
37	39	39	39	39	39	39

IMPACT MONO

MONO series constitutes a single, integrated unit. Since hydraulic connections are led, it is necessary to use the anti-freeze function, which prevents refrigerant from freezing. Strengths of the monoblock systems (as compared to the split systems):

- ▶ No individual hydraulic module provides space saving inside the building.
- ▶ Installers are not required to hold the F-gas certificate.
- ▶ Installation of a single unit.



Exemplary applications

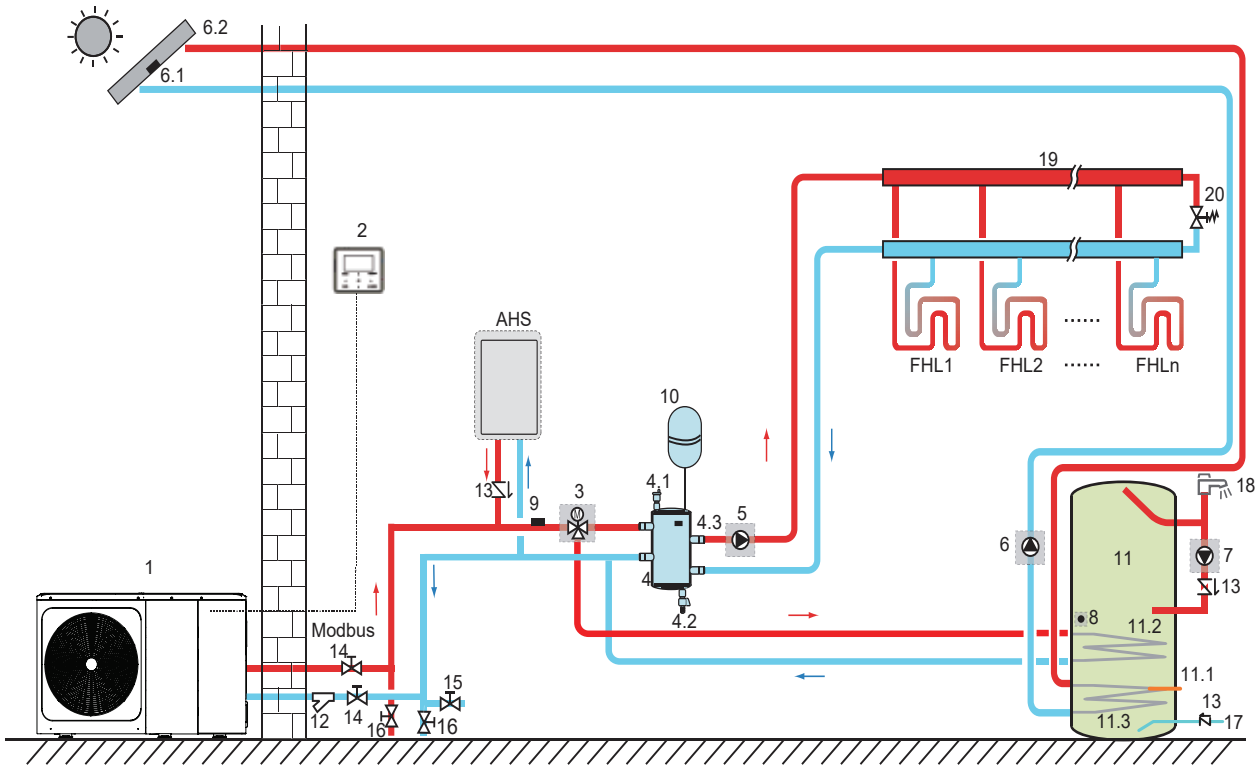

System no. 3: Installation with the Monoblock system, using solar collector management function

The diagram shown above uses the solar collector management function. The solar thermistor sends an appropriate signal to activate the solar pump and supply the domestic hot water tank.

Floor heating loops, fan coils and aluminum radiators can be used in heating mode. The cooling mode is implemented with use of fan-coils. The sensor in the low loss header is used to control the operation of the heat pump (on or off). When the water heats up, the IMPACT heat pump stops to save energy and extend the life of the unit, and then the expansion tank supplies hot water to the central heating system.

1	Outdoor unit	11	DHW tank (field supply)
2	User control panel	11.1 TBH	DHW tank booster heater (field supply)
3 SV1	3-way valve (field supply)	11.2	Coil 1: heat pump heat exchanger
4	Buffer tank (field supply)	11.3	Coil 2: solar collector heat exchanger
4.1	Automatic bleeder valve	12	Filter (extra equipment)
4.2	Drain valve	13	Check valve (field supply)
4.3 Tbt1	Top temperature sensor of the expansion tank (optional)	14	Stop valve (field supply)
4.4 Tbt2	Bottom temperature sensor of the expansion tank (optional)	15	Filling valve (field supply)
5 P_o	External circulation pump (field supply)	16	Drain valve (field supply)
6 P_s	Solar pump (field supply)	17	Water supply line (field supply)
6.1 Tsolar	Solar collectors temperature sensor (field supply)	18	Hot water tap (field supply)
6.2	Solar collectors (field supply)	19	Distributor/collector (field supply)
7	DHW pump (field supply)	20	By-pass valve (field supply)
8 T5	DHW tank temperature sensor (extra equipment)	FHL.1	Floor heating (field supply)
9 T1	Supply water temperature sensor (optional) AHS	AHS	Additional heat source (field supply)
10	Expansion tank (field supply)		

Specifications

Model			AHPM-V4W/ D2N8-BE30	AHPM-V6W/ D2N8-BE30	AHPM-V8W/ D2N8-BE30	AHPM-V10W/ D2N8-BE30	AHPM-V12W/ D2N8-BE30
Power supply (voltage/phases/frequency)		(V/-/Hz)	220-240/1/50	220-240/1/50	220-240/1/50	220-240/1/50	220-240/1/50
Heating (1) (A7/W35)	Capacity	kW	4.20	6.35	8.40	10.00	12.10
	COP	-	5.10	4.95	5.15	4.95	4.95
Heating (2) (A7/W45)	Capacity	kW	4.30	6.30	8.10	10.00	12.30
	COP	-	3.80	3.70	3.85	3.75	3.70
Cooling (3) (A35/W7)	Capacity	kW	4.70	7.00	7.45	8.20	11.50
	EER	-	3.45	3.00	3.35	3.25	2.75
Cooling (3) (A35/W18)	Capacity	kW	4.50	6.50	8.30	9.90	12.00
	EER	-	5.50	4.80	5.05	4.55	3.95
Electric heater power		kW	3	3	3	3	3
Seasonal energy efficiency class (4)	Water inlet temperature 35°C	-	A+++	A+++	A+++	A+++	A+++
	Water inlet temperature 55°C	-	A++	A++	A++	A++	A++
Outdoor temperature range	Cooling	°C	-5~43	-5~43	-5~43	-5~43	-5~43
	Heating	°C	-25~35	-25~35	-25~35	-25~35	-25~35
	Domestic hot water	°C	-25~43	-25~43	-25~43	-25~43	-25~43
Water inlet temperature range	Cooling	°C	5~25	5~25	5~25	5~25	5~25
	Heating	°C	25~65	25~65	25~65	25~65	25~65
	Domestic hot water	°C	20~60	20~60	20~60	20~60	20~60
Sound power level		dB(A)	55	58	59	60	65
Sound pressure level (5)		dB(A)	45.0	47.5	48.5	50.5	53.5
Outdoor fan	Motor type/no. of fans	-	DC/1	DC/1	DC/1	DC/1	DC/1
Refrigerant (type/charge)		-/kg	R32/1.4	R32/1.4	R32/1.4	R32/1.4	R32/1.75
Dimensions (length/height/depth)		mm	1295×718×429	1295×718×429	1385×865×526	1385×865×526	1385×865×526
Transport dimensions (length/height/depth)		mm	1375×885×475	1375×885×475	1465×1035×560	1465×1035×560	1465×1035×560
Net/gross weight		kg	86/107	86/107	105/132	105/132	129/155

(1) DB/WB 7/6°C, LWT 35°C ($\Delta T = 5^\circ\text{C}$)

(2) DB/WB 7/6°C, LWT 45°C ($\Delta T = 5^\circ\text{C}$)

(3) DB 35°C, LWT 18°C ($\Delta T = 5^\circ\text{C}$)

(4) Seasonal space heating energy efficiency class tested in average climate conditions.

(5) Sound pressure level measured at a distance of 1 m from the unit and $(1+H)/2\text{m}$ (where H is the height of the unit) above the floor in the semi-anechoic chamber.

The sound pressure level is tested in the following conditions:

Outdoor air temperature 7°C DB, 85% R.H.; inlet water temperature 30°, outlet water temperature 35°C.

Outdoor air temperature 7°C DB, 85% R.H.; inlet water temperature 47°, outlet water temperature 55°C.

Related standards and legislation: EN14511; EN14825; EN50564; EN12102; (EU) No 811/2013; (EU) No 813/2013; OJ 2014/C 207

AHPM-V14W/ D2N8-BE30	AHPM-V16W/ D2N8-BE30	AHPM-V12W/ D2RN8-BER90	AHPM-V14W/ D2RN8-BER90	AHPM-V16W/ D2RN8-BER90	AHPM-V18W/ D2RN8	AHPM-V22W/ D2RN8	AHPM-V26W/ D2RN8	AHPM-V30W/ D2RN8
220-240/1/50	220-240/1/50	380-415/3/50	380-415/3/50	380-415/3/50	380-415/3/50	380-415/3/50	380-415/3/50	380-415/3/50
14.50	15.90	12.10	14.50	15.90	18.00	22.00	26.00	30.10
4.60	4.50	4.95	4.60	4.50	4.70	4.40	4.08	3.91
14.10	16.00	12.30	14.10	16.00	18.00	22.00	26.00	30.00
3.60	3.50	3.70	3.60	3.50	3.50	3.40	3.10	2.90
12.40	14.00	11.50	12.40	14.00	17.00	21.00	26.00	29.50
2.50	2.50	2.75	2.50	2.50	3.05	2.95	2.70	2.55
13.50	14.90	12.00	13.50	14.90	18.50	23.00	27.00	31.00
3.60	3.40	3.95	3.60	3.40	4.75	4.60	4.30	4.00
3	3	3/6/9	3/6/9	3/6/9	-	-	-	-
A+++	A+++	A+++	A+++	A+++	A+++	A+++	A+++	A++
A++	A++	A++	A++	A++	A++	A++	A+	A+
-5~43	-5~43	-5~43	-5~43	-5~43	-5~46	-5~46	-5~46	-5~46
-25~35	-25~35	-25~35	-25~35	-25~35	-25~35	-25~35	-25~35	-25~35
-25~43	-25~43	-25~43	-25~43	-25~43	-25~43	-25~43	-25~43	-25~43
5~25	5~25	5~25	5~25	5~25	5~25	5~25	5~25	5~25
25~65	25~65	25~65	25~65	25~65	25~60	25~60	25~60	25~60
20~60	20~60	20~60	20~60	20~60	30~60	30~60	30~60	30~60
65	68	65	65	68	71	73	75	77
54	58	53.5	54	58	57.6	59.8	61.5	63.5
DC/1	DC/1	DC/1	DC/1	DC/1	DC/2	DC/2	DC/2	DC/2
R32/1.75	R32/1.75	R32/1.75	R32/1.75	R32/1.75	R32/5	R32/5	R32/5	R32/5
1385×865×526	1385×865×526	1385×865×526	1385×865×526	1385×865×526	1129×1558×440	1129×1558×440	1129×1558×440	1129×1558×440
1465×1035×560	1465×1035×560	1465×1035×560	1465×1035×560	1465×1035×560	1220×1735×565	1220×1735×565	1220×1735×565	1220×1735×565
129/155	129/155	144/172	144/172	144/172	177/206	177/206	177/206	177/206

Unit dimensions

IMPACT SPLIT and IMPACT All-In-One
 – outdoor unit 4/6 kW

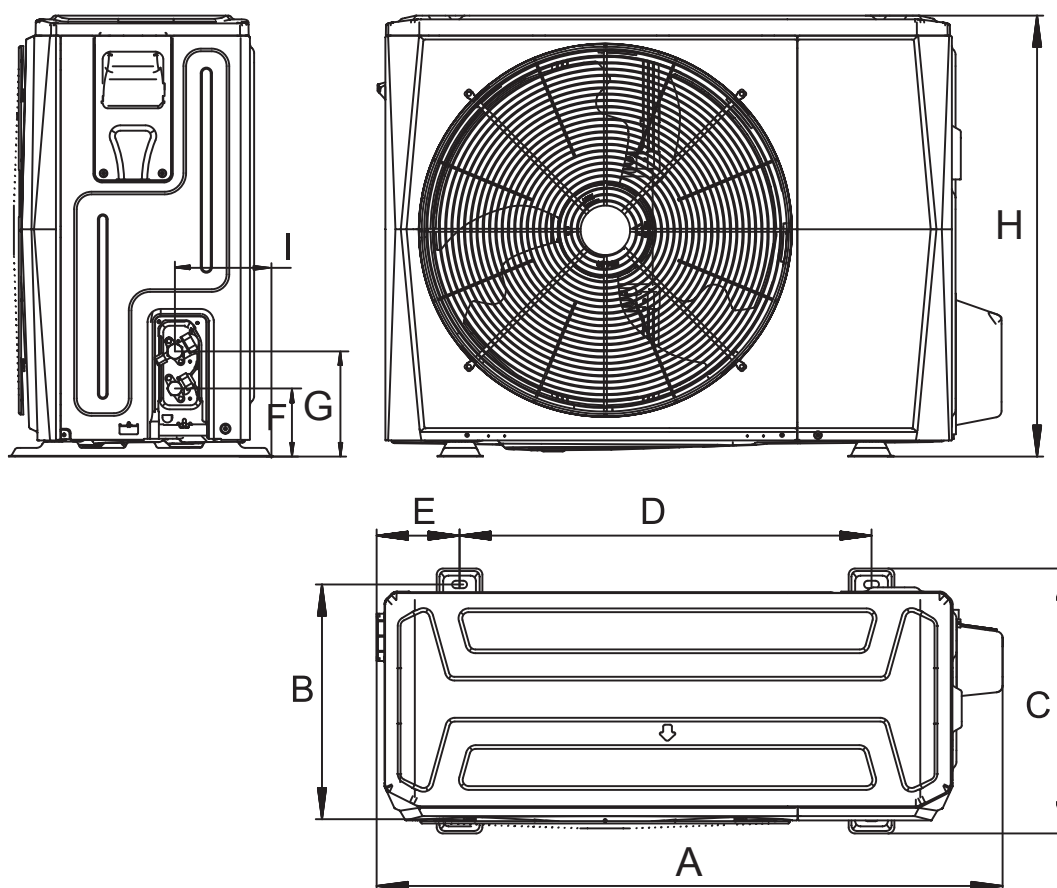

Model		AHPS-V4W/D2N8-B	AHPS-V6W/D2N8-B
Dimensions A/H/C (length/height/depth)	mm	1008/712/426	1008/712/426
Dimensions B/D/E	mm	375/663/134	375/663/134
Dimensions F/G/I	mm	110/170/160	110/170/160
Transport dimensions (length/height/depth)	mm	1065/810/485	1065/810/485
Net/gross weight	kg	58/63.5	58/63.5

IMPACT SPLIT and IMPACT All-In-One

– outdoor unit 8/10/12/14/16 kW

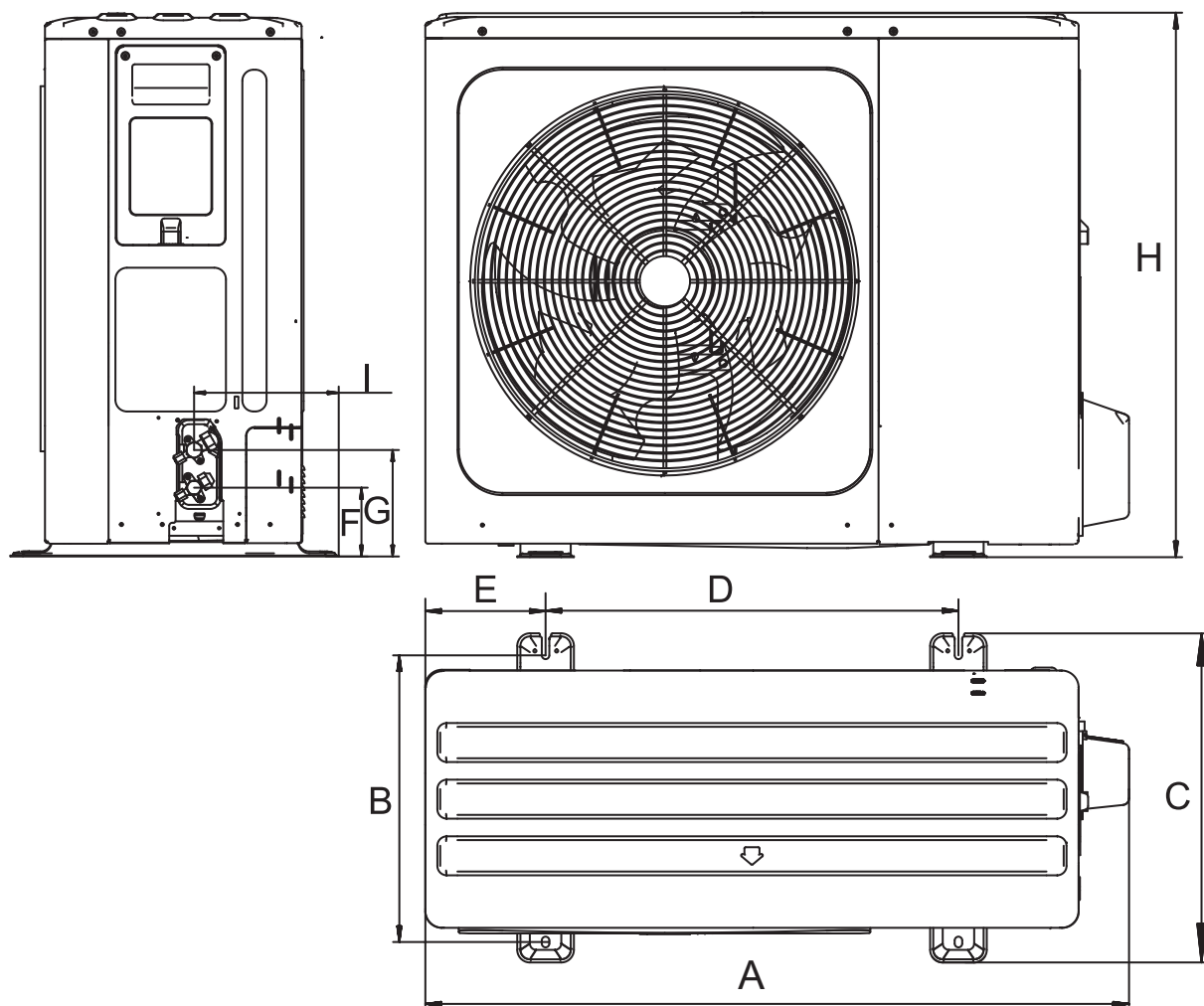

Model	AHPS-V8W/ D2N8-B	AHPS-V10W/ D2N8-B	AHPS-V12W/ D2N8-B	AHPS-V14W/ D2N8-B
Dimensions (length/height/depth)	mm	1118/865/523	1118/865/523	1118/865/523
Dimensions B/D/E	mm	456/656/191	456/656/191	456/656/191
Dimensions F/G/I	mm	110/170/230	110/170/230	110/170/230
Transport dimensions (length/height/depth)	mm	1180/970/560	1180/970/560	1180/970/560
Net/gross weight	kg	75/89	75/89	97/110.5

Model	AHPS-V16W/ D2N8-B	AHPS-V12W/ D2RN8-B	AHPS-V14W/ D2RN8-B	AHPS-V16W/ D2RN8-B
Dimensions (length/height/depth)	mm	1118/865/523	1118/865/523	1118/865/523
Dimensions B/D/E	mm	456/656/191	456/656/191	456/656/191
Dimensions F/G/I	mm	110/170/230	110/170/230	110/170/230
Transport dimensions (length/height/depth)	mm	1180/970/560	1180/970/560	1180/970/560
Net/gross weight	kg	97/110.5	112/125.5	112/125.5

IMPACT SPLIT – hydraulic module

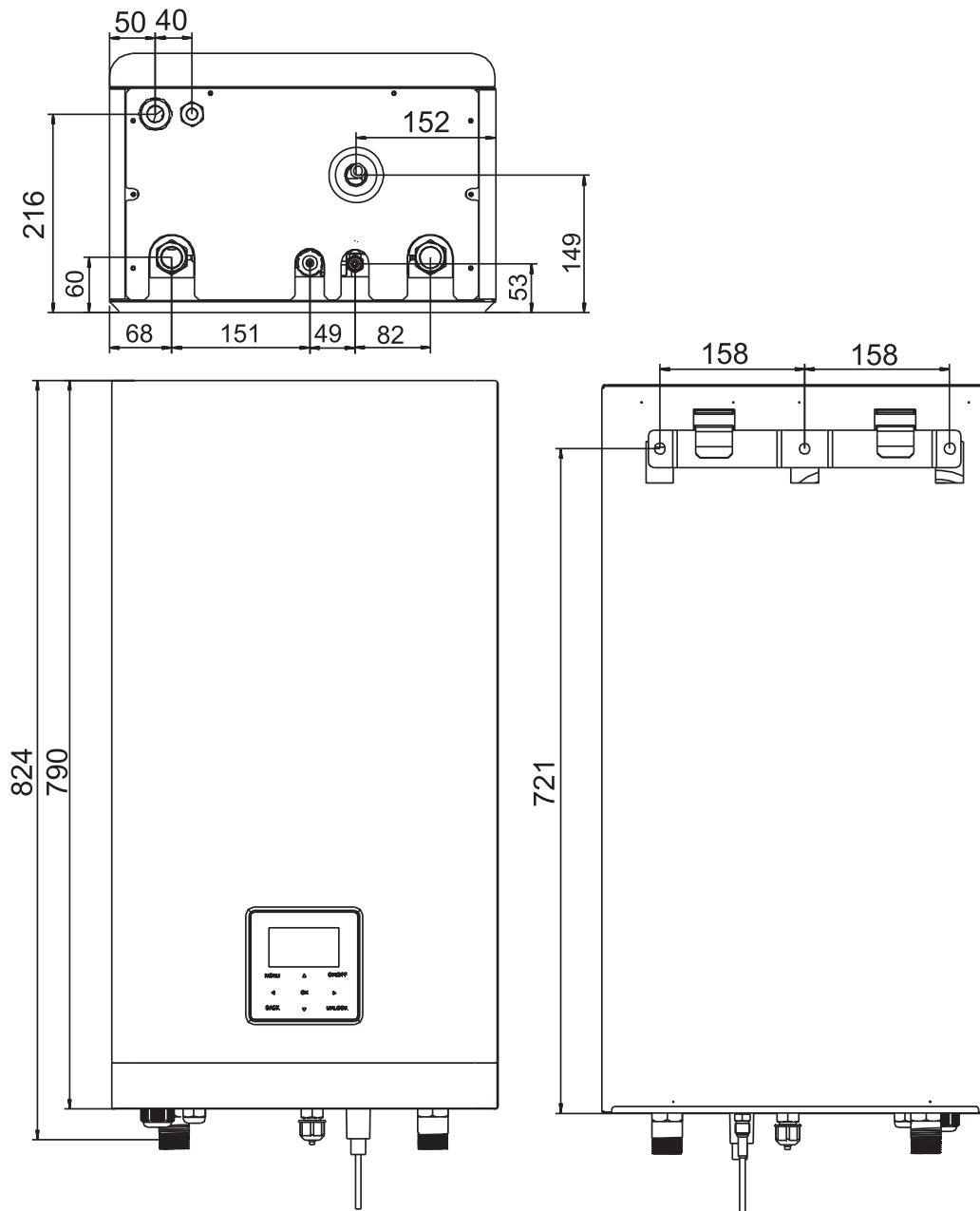

Model		AHB-A60/CD30GN8-B	AHB-A100/CDS90GN8-B	AHB-A160/CGS90GN8-B
Dimensions (length/height/depth)	mm	420/790/270	420/790/270	420/790/270
Transport dimensions (length/height/depth)	mm	525/1050/360	525/1050/360	525/1050/360
Net/gross weight	kg	37/43	37/43	39/45

IMPACT All-In-One – hydraulic module

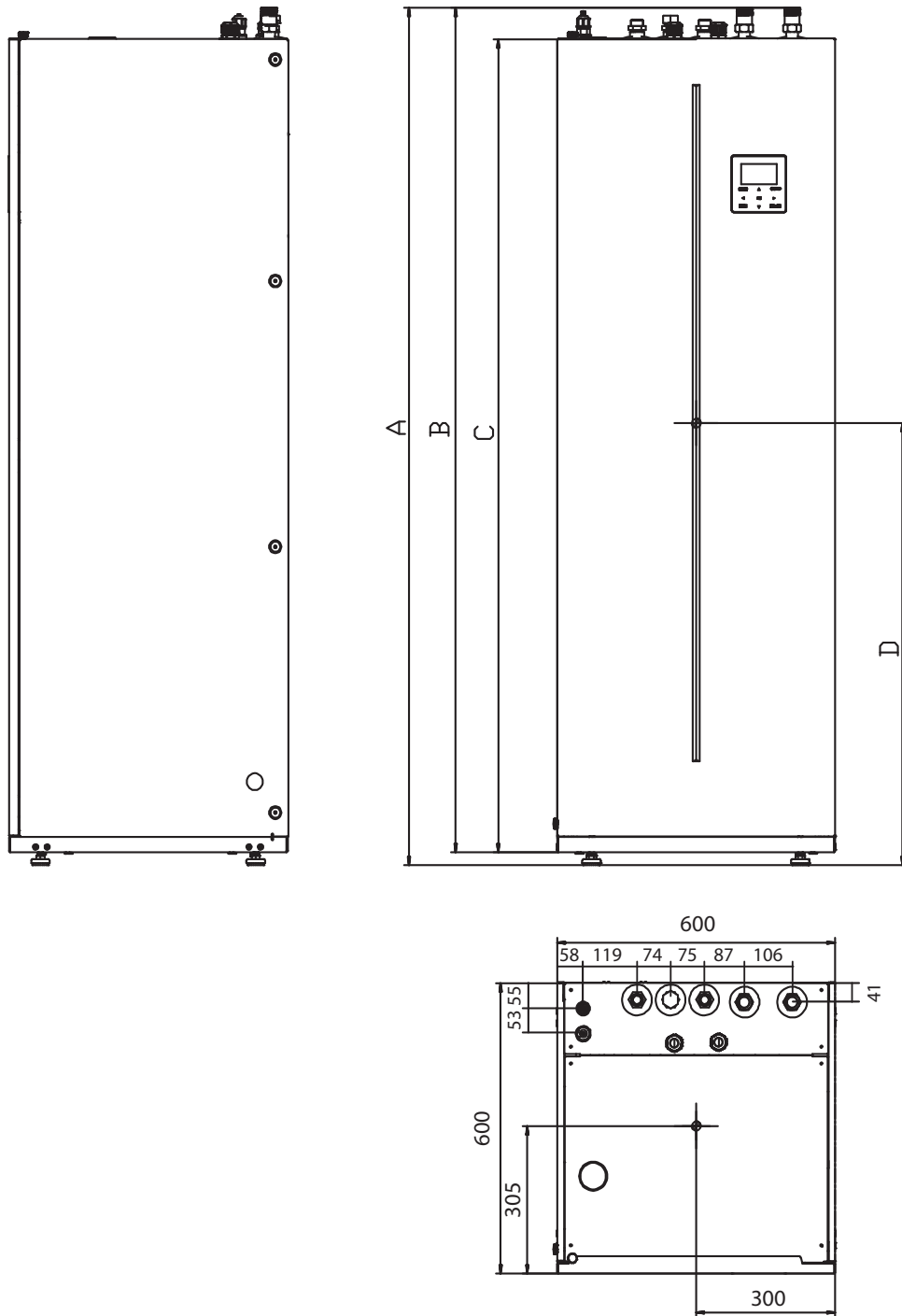

Model		AHBT-A100/ 190CD30GN8-B	AHBT-A100/ 240CD30GN8-B	AHBT-A100/ 190CDS90GN8-B	AHBT-A100/ 240CDS90GN8-B	AHBT-A160/ 240CGS90GN8-B
A/B/C/D	mm	1775/1748/1682 /915	2034/2007/1942 /1045	1775/1748/1682 /915	2034/2007/1942 /1045	2034/2007/1942 /1045
Transport dimensions (length/height/depth)	mm	653/1900/653	653/2160/653	653/1900/653	653/2160/653	653/2160/653
Net/gross weight	kg	140/161	157/178	140/161	157/178	159/180

IMPACT MONO – outdoor unit 4/6 kW

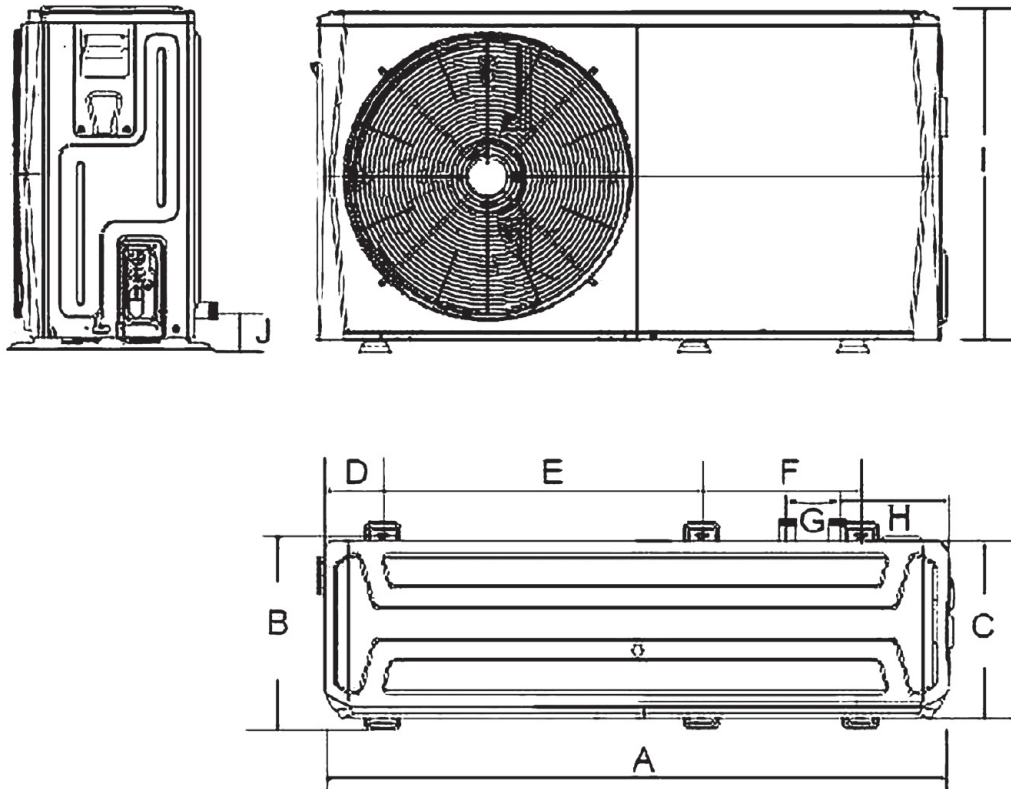

Model		AHPM-V4W/D2N8-BE30	AHPM-V6W/D2N8-B30
Dimensions A/I/C (length/height/depth)	mm	1295/718/429	1295/718/429
Dimensions B/D/E/F	mm	401/115/638/379	401/115/638/379
Dimensions G/H/J	mm	105/225/161	105/225/161
Transport dimensions (length/height/depth)	mm	1375/885/485	1375/885/485
Net/gross weight	kg	86/107	86/107

IMPACT MONO – outdoor unit 8/10/12/14/16 kW

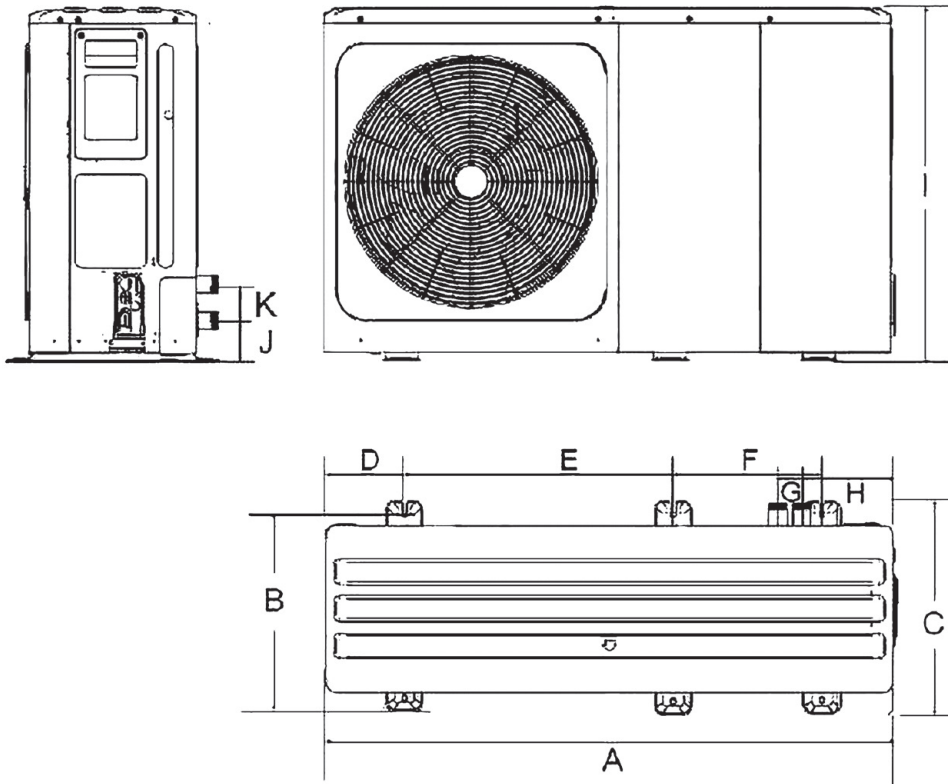

Model	AHPM-V8W/ D2N8-BE30	AHPM-V10W/ D2N8-BE30	AHPM-V12W/ D2N8-BE30	AHPM-V14W/ D2N8-BE30
Dimensions A/I/C (length/height/depth)	mm 1385/865/526	mm 1385/865/526	mm 1385/865/526	mm 1385/865/526
Dimensions B/D/E/F	mm 488/192/656/363	mm 488/192/656/363	mm 488/192/656/363	mm 488/192/656/363
Dimensions G/H/J/K	mm 60/221/182/81	mm 60/221/182/81	mm 60/221/182/81	mm 60/221/182/81
Transport dimensions (length/height/depth)	mm 1465/1035/560	mm 1465/1035/560	mm 1465/1035/560	mm 1465/1035/560
Net/gross weight	kg 105/132	kg 105/132	kg 129/155	kg 129/155

Model	AHPM-V16W/ D2N8-BE30	AHPM-V12W/ D2N8-BER90	AHPM-V14W/ D2N8-BER90	AHPM-V16W/ D2N8-BER90
Dimensions A/I/C (length/height/depth)	mm 1385/865/526	mm 1385/865/526	mm 1385/865/526	mm 1385/865/526
Dimensions B/D/E/F	mm 488/192/656/363	mm 488/192/656/363	mm 488/192/656/363	mm 488/192/656/363
Dimensions G/H/J/K	mm 60/221/182/81	mm 60/221/182/81	mm 60/221/182/81	mm 60/221/182/81
Transport dimensions (length/height/depth)	mm 1465/1035/560	mm 1465/1035/560	mm 1465/1035/560	mm 1465/1035/560
Net/gross weight	kg 129/155	kg 144/172	kg 144/172	kg 144/172

IMPACT MONO – outdoor unit 18/22/26/30 kW

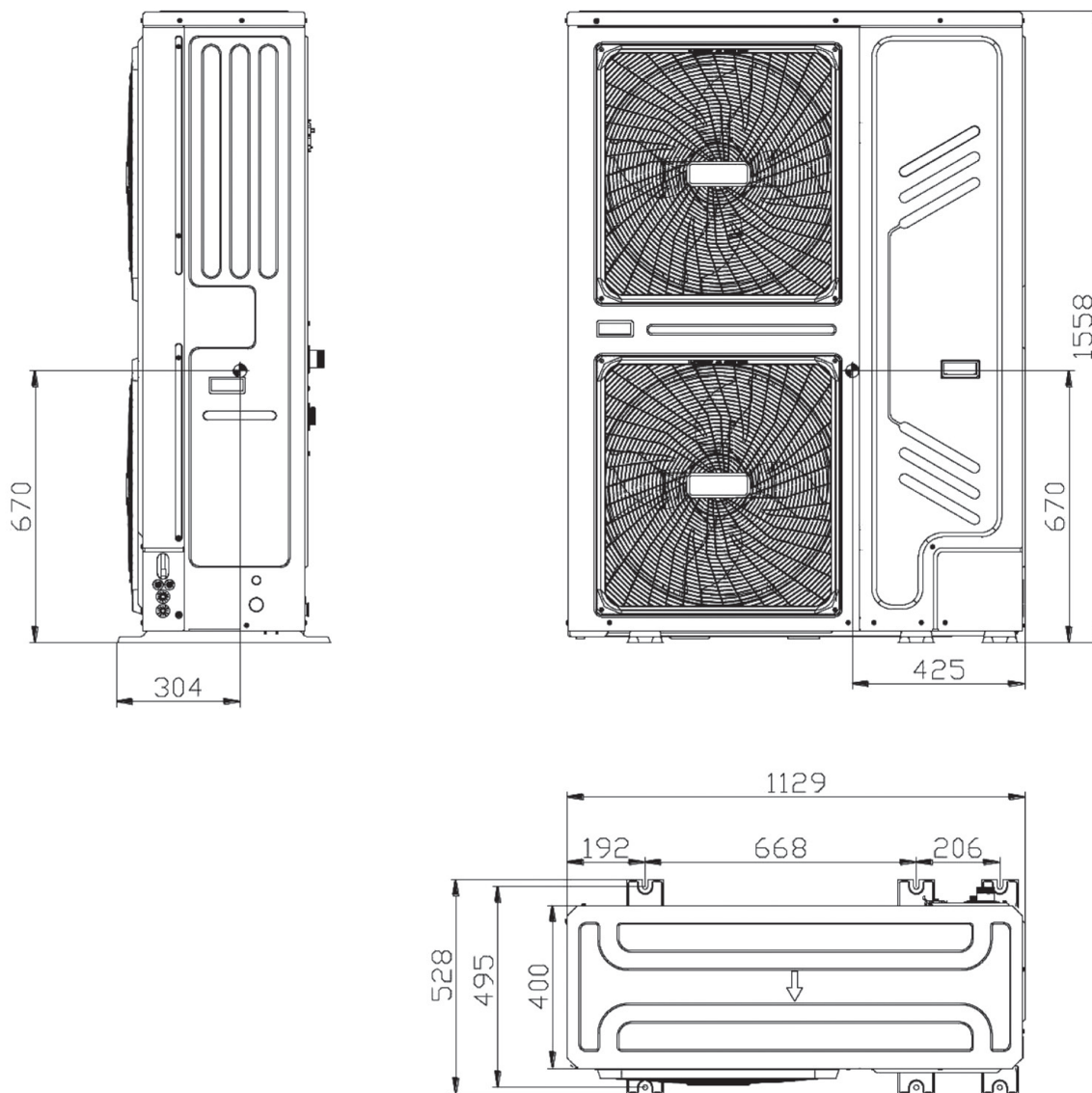

Model		AHPM-V18W/D2RN8	AHPM-V22W/D2RN8	AHPM-V26W/D2RN8	AHPM-V30W/D2RN8
Dimensions (length/height/depth)	mm	1129/1558/440	1129/1558/440	1129/1558/440	1129/1558/440
Transport dimensions (length/height/depth)	mm	1220/1735/565	1220/1735/565	1220/1735/565	1220/1735/565
Net/gross weight	kg	177/206	177/206	177/206	177/206

Aircon – Product Information

New series of SPLIT air-conditioners

All Easy '22



Multi Function Board



Alarm port



Vertical/horizontal louver

Aroma '22



8°C heating (Frost Protect)



Ionizer



Drain pan heater

OASIS

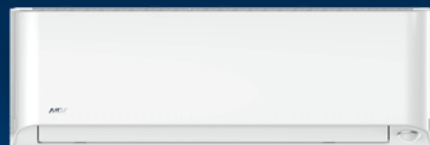

Wi-Fi Control



Intelligent eye



Drain pan heater

Office Standard Series – for commercial air-conditioner systems

Indoor units:

- Duct type
- Ceiling-floor type
- Standard cassette
- Compact cassette



VRF Outdoor units

Capacity:

seria ONE – from 7,2 to 90 kW

seria EVO – from 25 to 61,5 kW

with possible extension up to 246 kW

ONE serie



EVO serie



MDV General Representative in Slovakia

mdvslovakia.sk